

HORIZON GLIDER BENCH PAGE 1

HZ-0301

BREEZESTA™
Recycled Poly Furniture

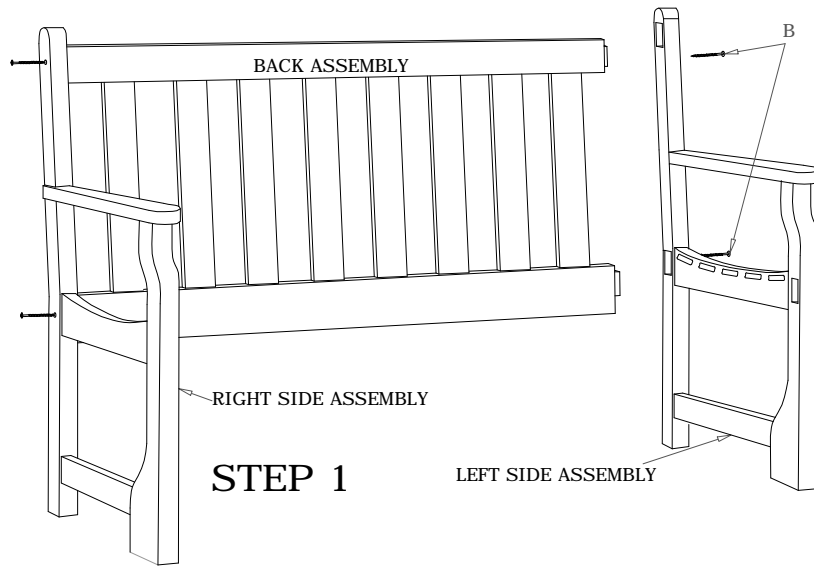

Attach Side Assemblies to Back Assemblies using screws (B) as shown.

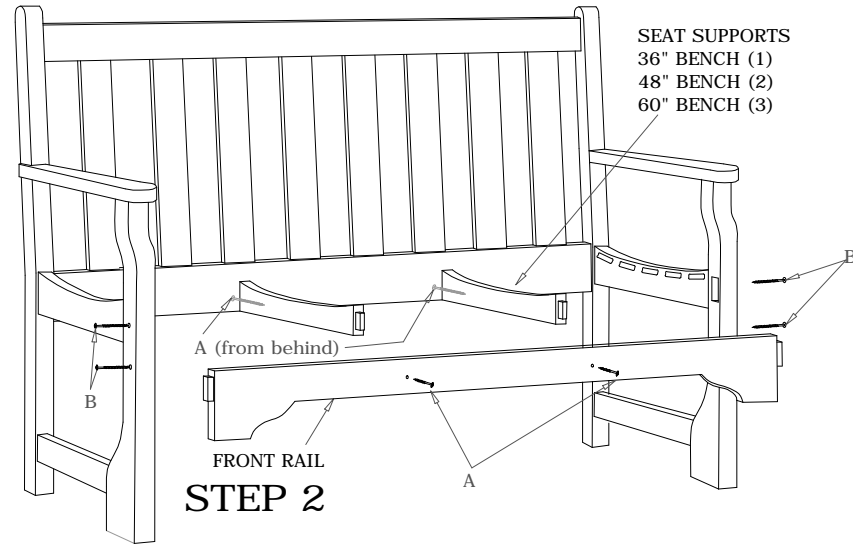

Attach Front Rail using screws (B) with the metal support to the inside. Place Seat Supports in place and screw through Back Assembly with screws (B) and through front rail with screws (A).

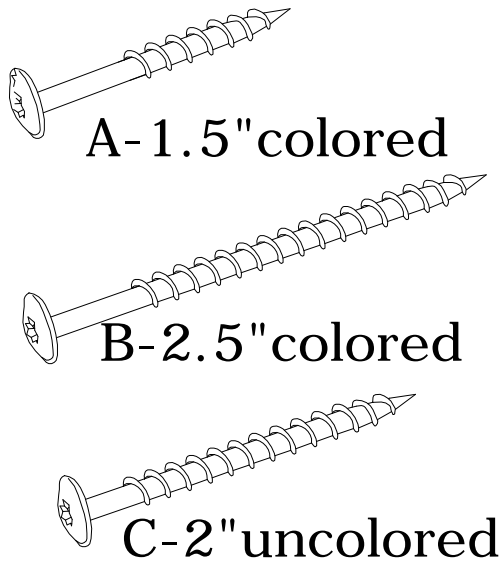

- LIST OF PARTS**
 Back Assembly (1)
 Left End Assembly (1)
 Right End Assembly (1)
 Seat Supports (see chart)
 Seat Slats (5)
 Hardware (see chart)
 Insert Bit Tool (1)

Bench Size	36"	48"	60"
Seat Supports	1	2	3
Screw "A"	8	9	10
Screw "B"	8	9	10
Screw "C"	5	10	15

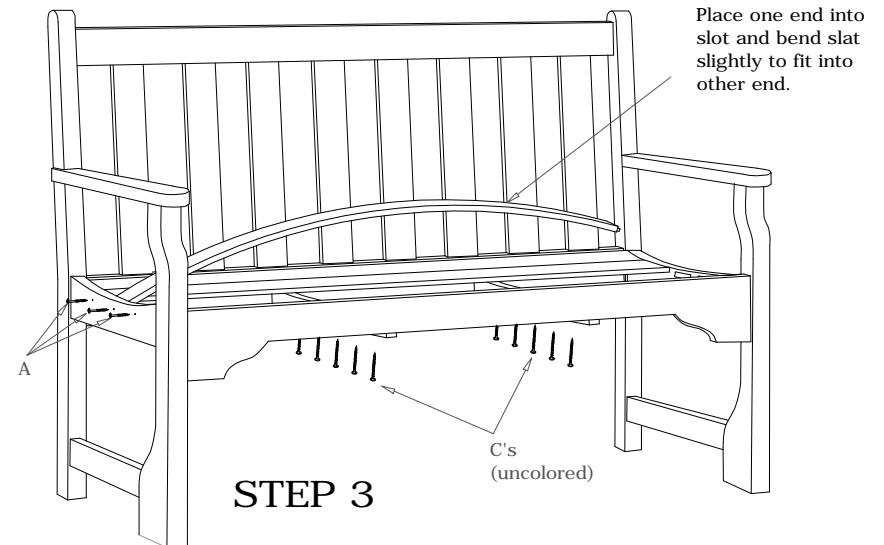

Fit seat slats into bench as shown. From the bottom side use uncolored screws (C) to secure slats. Use screws (A) to attach Side Assemblies to Slats.