

breezesta™

FLAT SEAT BAR STOOL

BH-0903

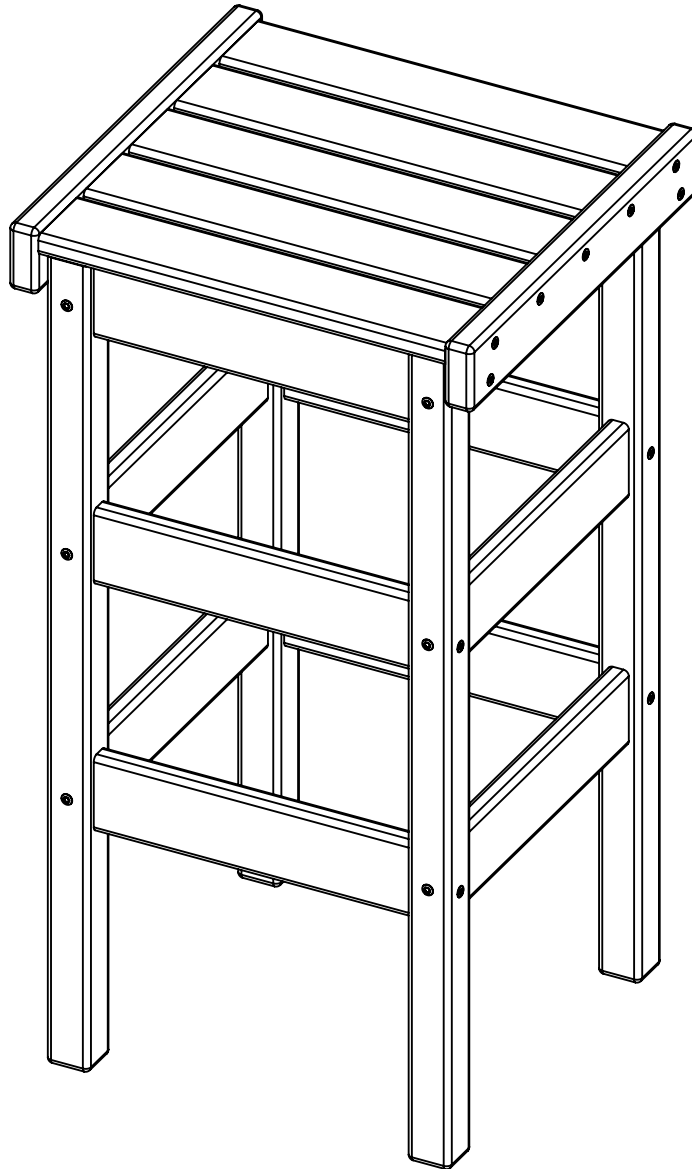

REV00-1/19

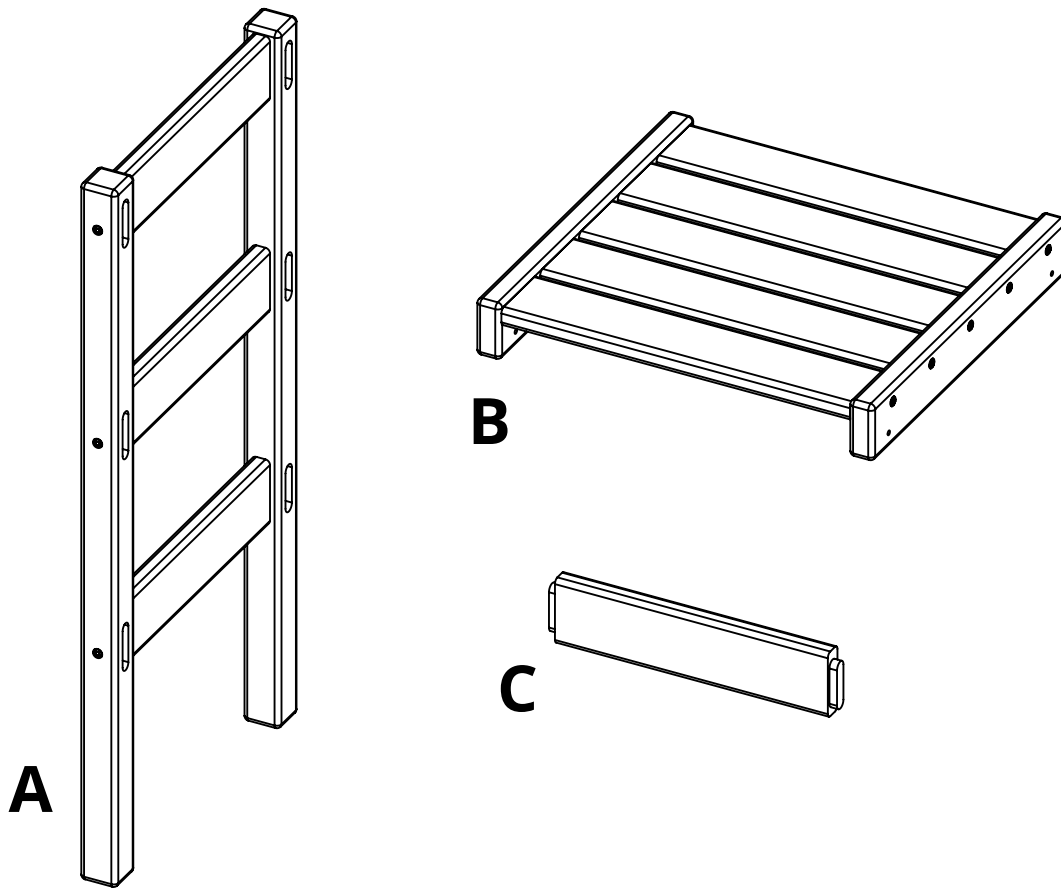

PARTS			
PART	DESCRIPTION	PART NO.	QTY
A	SIDE ASSEMBLY	SA-00152	2
B	SEAT ASSEMBLY	SA-00150	1
C	STOOL SPREADER	SS-11.25	6

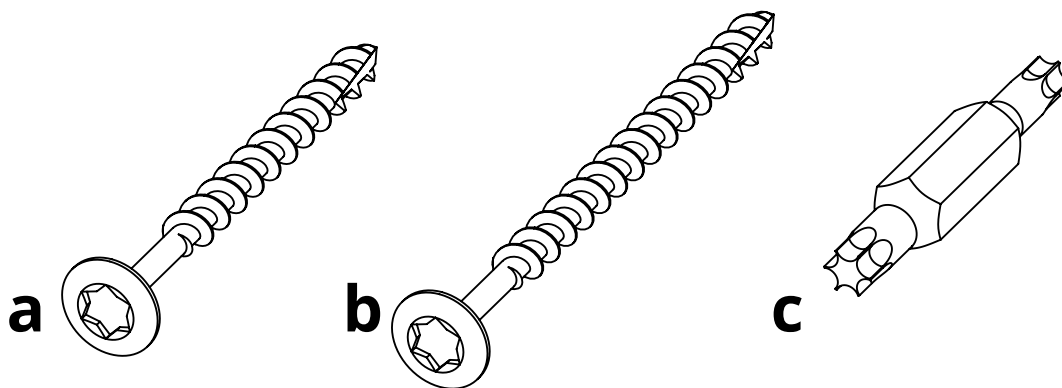

HARDWARE			
PART	DESCRIPTION	PART NO.	QTY
a	#8 X 2" TORX SCREW	H-0000-S82	12
b	#8 X 2-1/2" TORX SCREW	H-0000-S825	4
c	T20 & T25 TORX BIT	H-0000-CTD	1

Suggested Tools: Drill, Plastic Mallet

Please read entire instructions before beginning

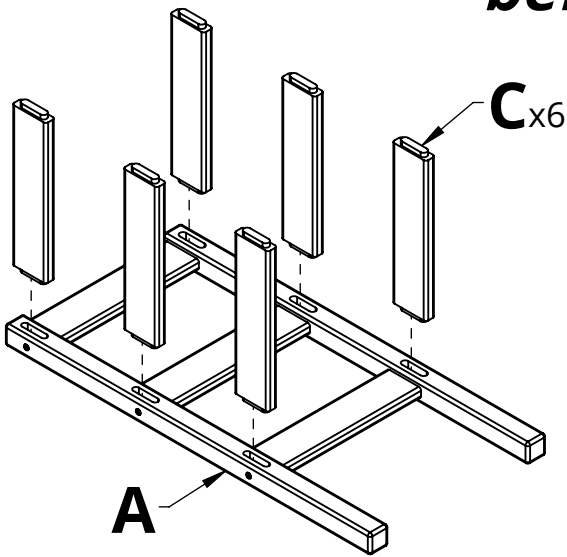

1. Place Part A on its side and insert Parts C into place as shown

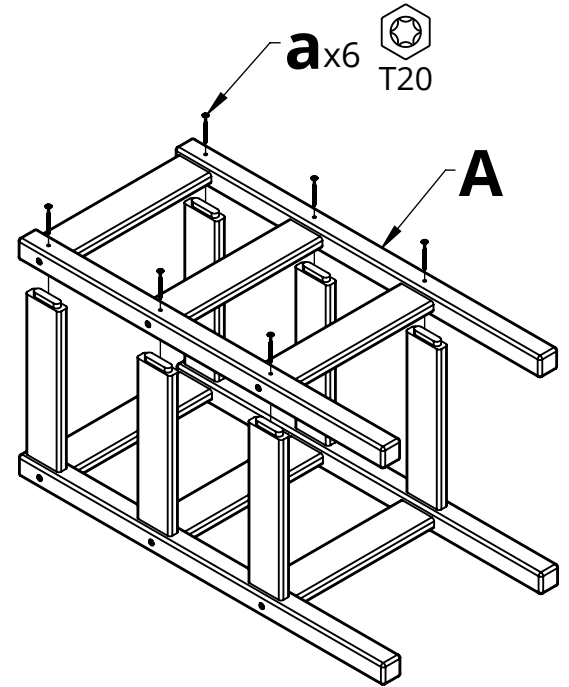

2. Place part A on top and connect with the hardware shown

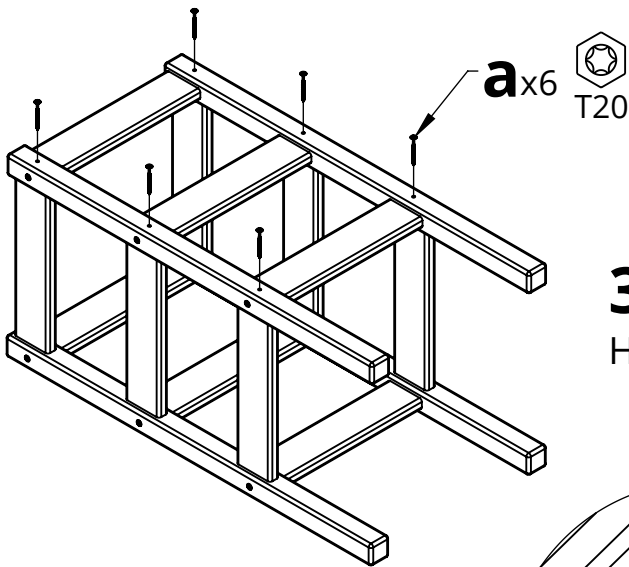

3. Turn the assembly over and insert Hardware a

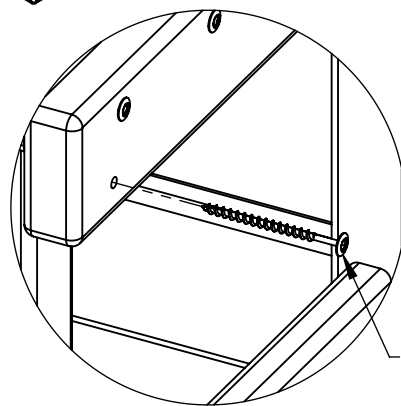

4. Stand the assembly upright and connect Part B with Hardware b

