

<b>PARTS</b>			
<b>PART</b>	<b>DESCRIPTION</b>	<b>PART NO.</b>	<b>QTY</b>
A	SIDE ASSEMBLY	SA-00312	2
B	SPREADER	PRT-00620	6
C	BASE SPREADER	PRT-00621	1
D	TABLE TOP ASSEMBLY 36"x 36"	SA-00325	1

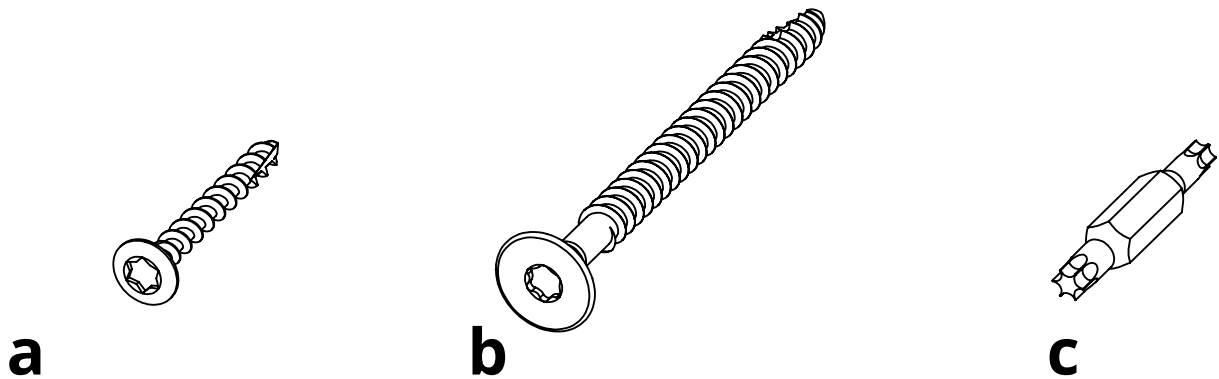

<b>HARDWARE</b>			
<b>PART</b>	<b>DESCRIPTION</b>	<b>PART NO.</b>	<b>QTY</b>
a	#8 X 2" TORX SCREW	H-0000-S82	4
b	1/4-10 x 3" LAG	H-0000-S103	28
e	T20 & T25 TORX BIT	H-0000-CTD	1

**Suggested Tools:** Drill, Plastic Mallet

# Please read entire instructions before beginning

1. Attach Part B and Part C to Part A using Hardware b

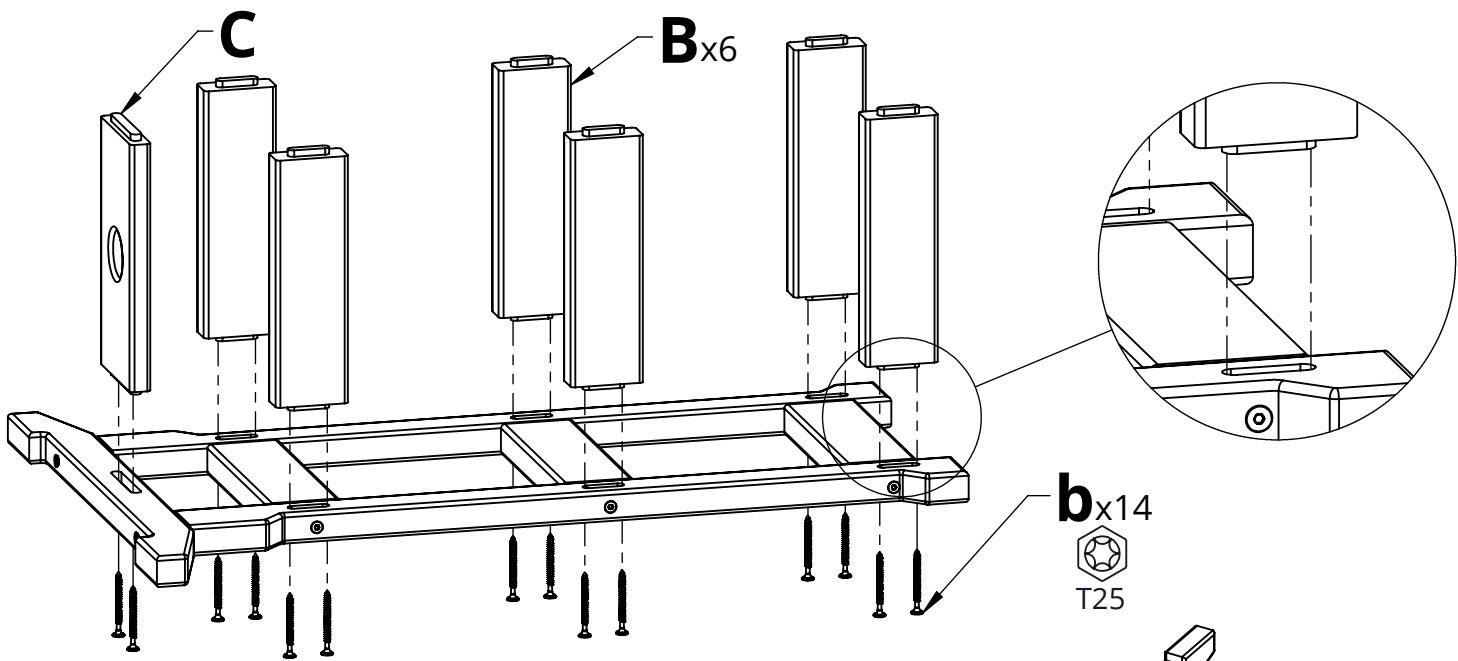

2. Place second Part A on assembled piece from Step 1; Repeat Step 1

3. Attach Part A onto Part D using Hardware a

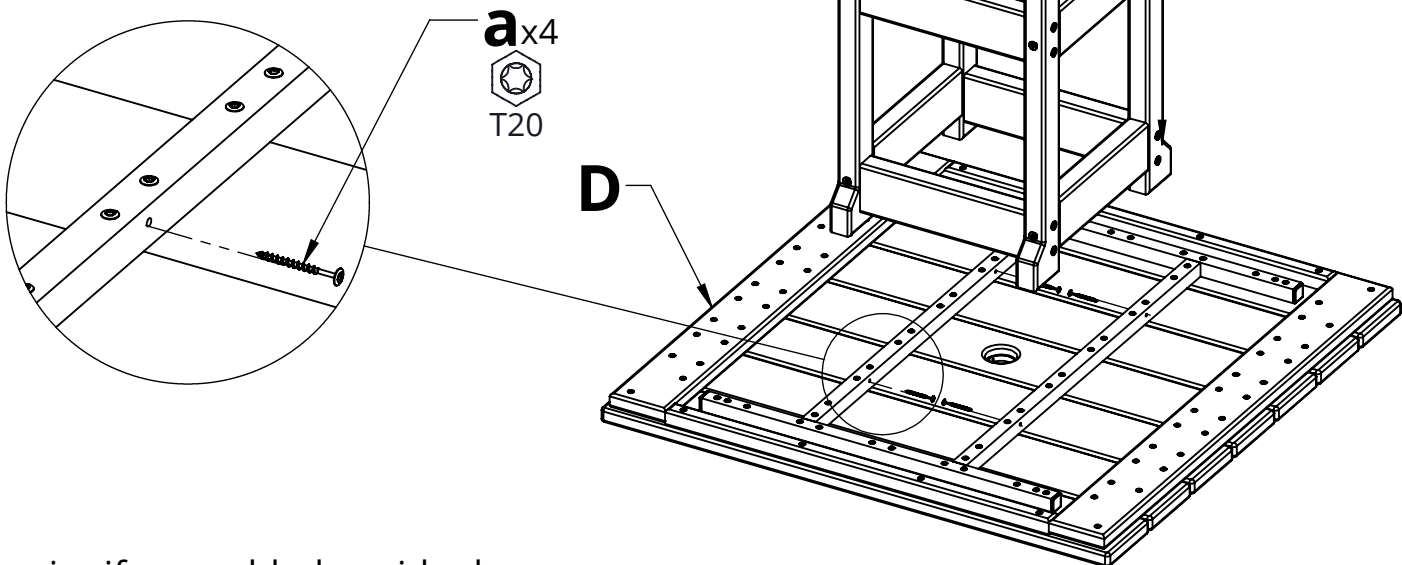

May be easier if assembled upside down