

breezesta™

**FLAT SEAT COUNTER STOOL**  
CH-0803

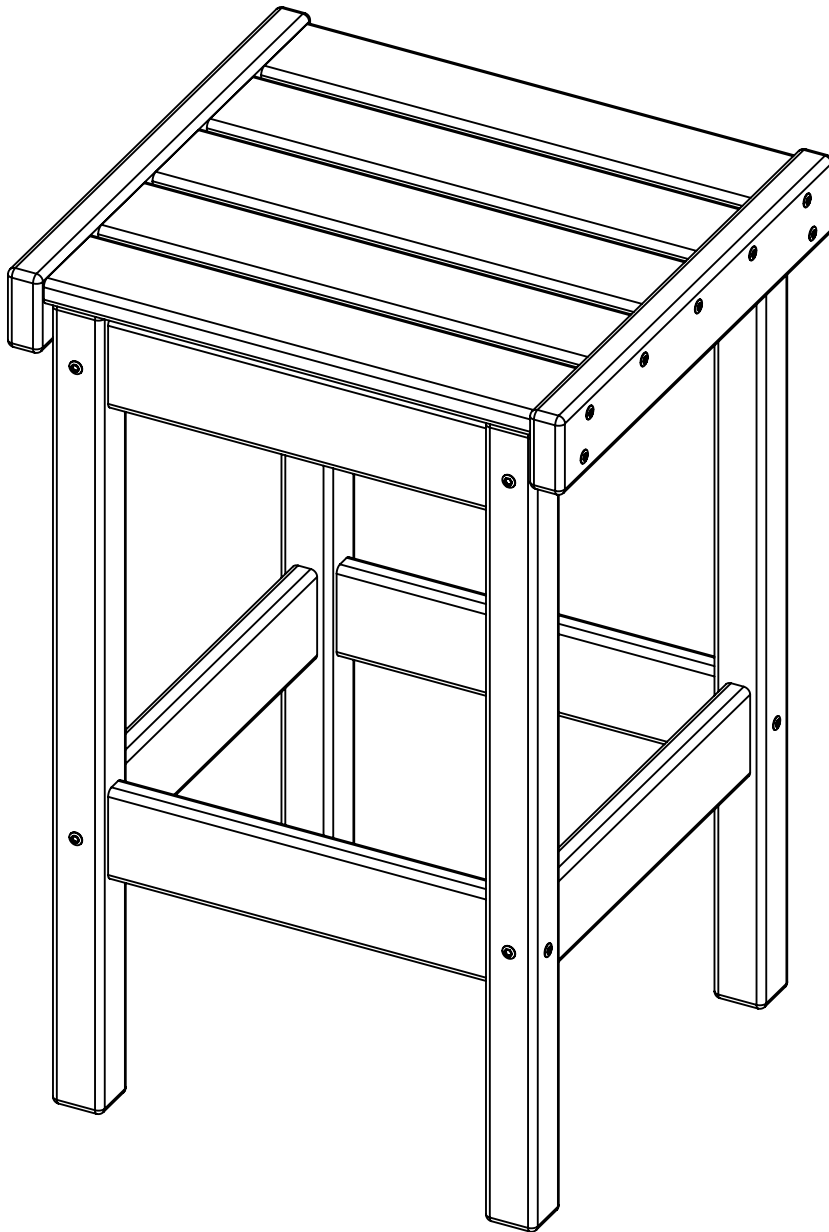

REV00-1/19

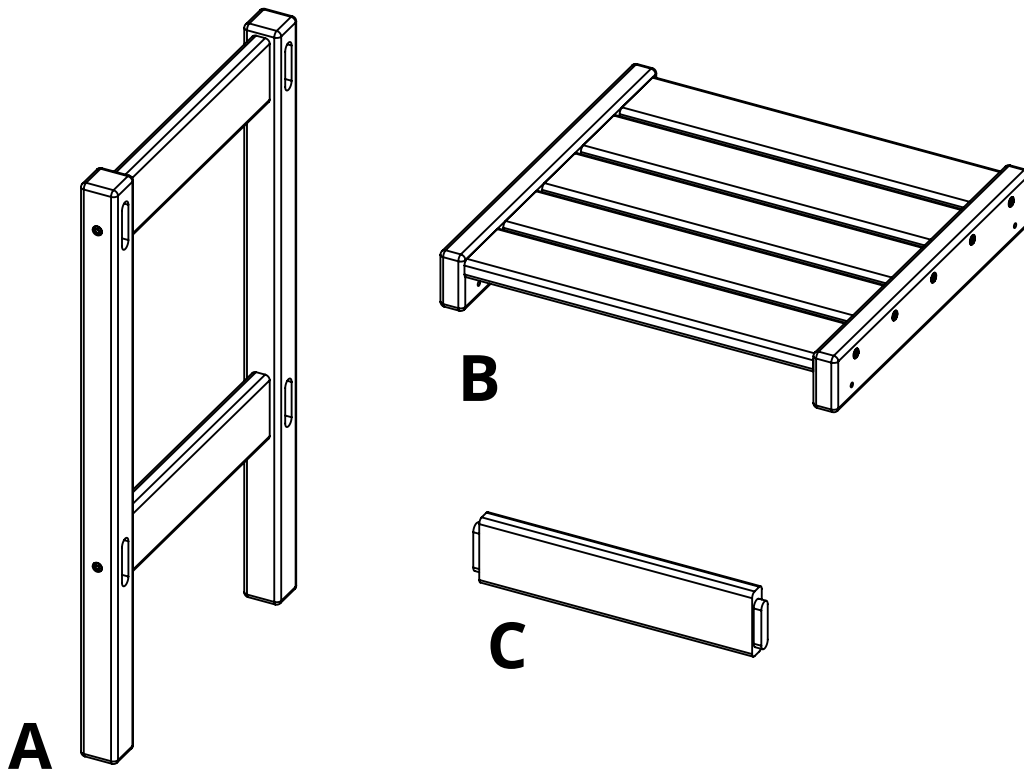

<b>PARTS</b>			
<b>PART</b>	<b>DESCRIPTION</b>	<b>PART NO.</b>	<b>QTY</b>
A	SIDE ASSEMBLY	SA-00149	2
B	SEAT ASSEMBLY	SA-00150	1
C	STOOL SPREADER	SS-11.25	4

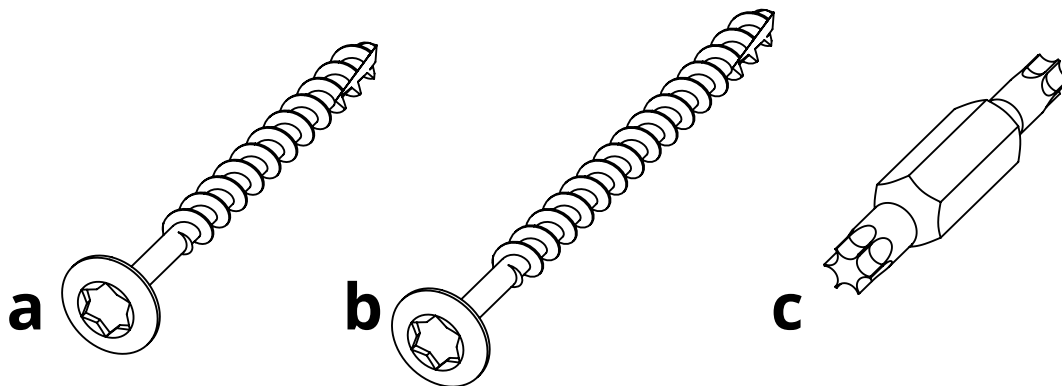

<b>HARDWARE</b>			
<b>PART</b>	<b>DESCRIPTION</b>	<b>PART NO.</b>	<b>QTY</b>
a	#8 X 2" TORX SCREW	H-0000-S82	8
b	#8 X 2-1/2" TORX SCREW	H-0000-S825	4
c	T20 & T25 TORX BIT	H-0000-CTD	1

**Suggested Tools:** Drill, Plastic Mallet

# Please read entire instructions before beginning

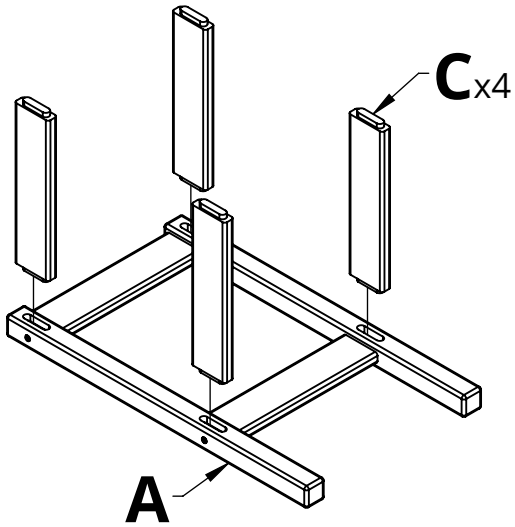

**1.** Place Part A on its side and insert Parts C into place as shown

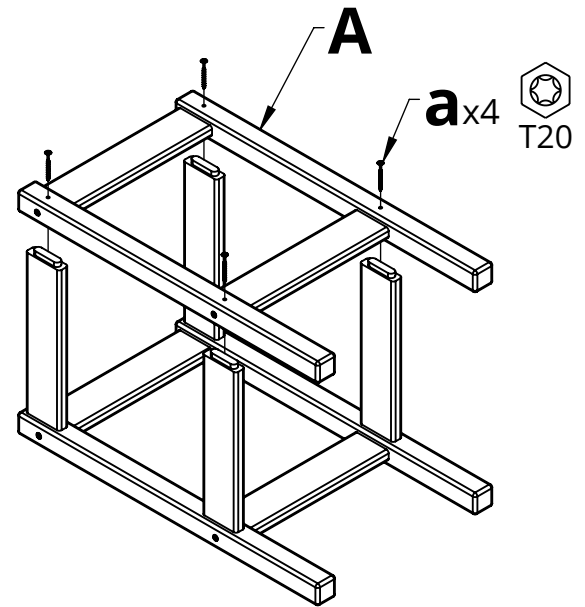

**2.** Place part A on top and connect with the hardware shown

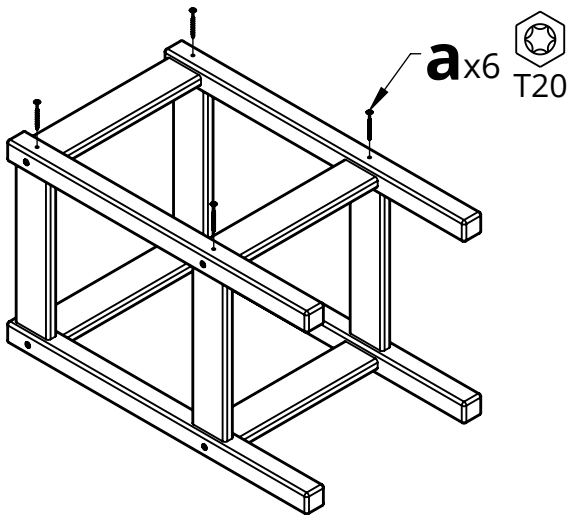

**3.** Turn the assembly over and insert Hardware a

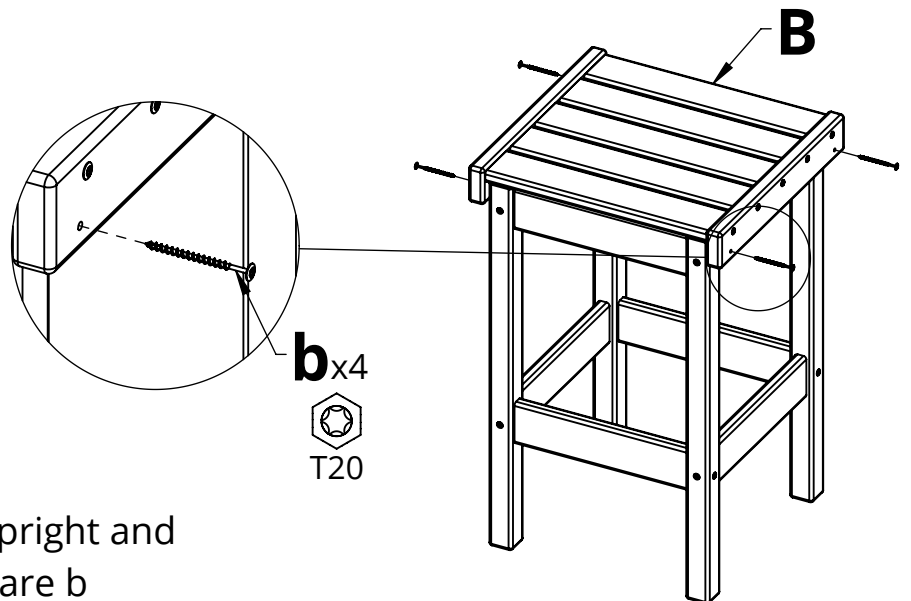

**4.** Stand the assembly upright and connect Part B with Hardware b