

FOLDING ADIRONDACK CHAIR

AD-0106

BREEZESTA tm

Recycled Poly Furniture

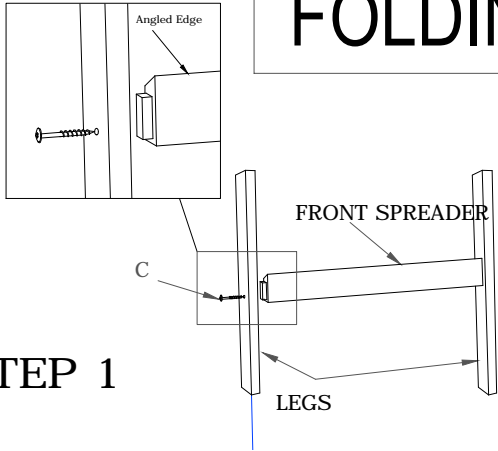

STEP 1

Attach Spreader tenon into mortise (pocket) on Legs and attach with screws (C) as shown. Bolt legs to Base Assembly using bolts (A).

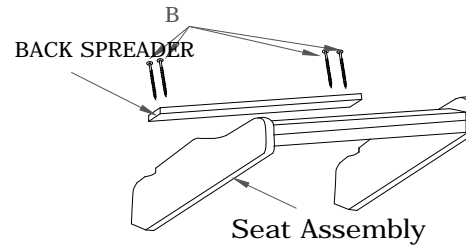

STEP 2

2. Tenons on the Back Assembly will fit into mortise (pocket) in Seat Assembly. Attach with Screws (B) as shown).

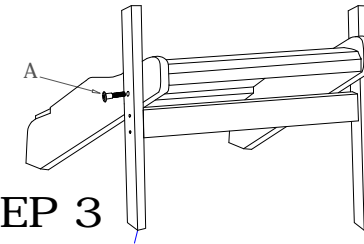

STEP 3

3. Attach Seat Assembly to Front Legs using Bolt (A). Bevel edge should face rear as shown in step 1.

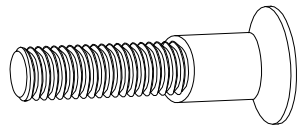

A-1.5" (6 pcs.)

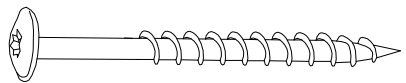

B-1.75" (4 pcs.)

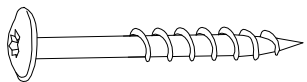

C-1.5" (2 pcs.)

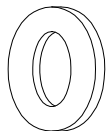

E- (6 pcs.)

D-3" (4 pcs.) painted

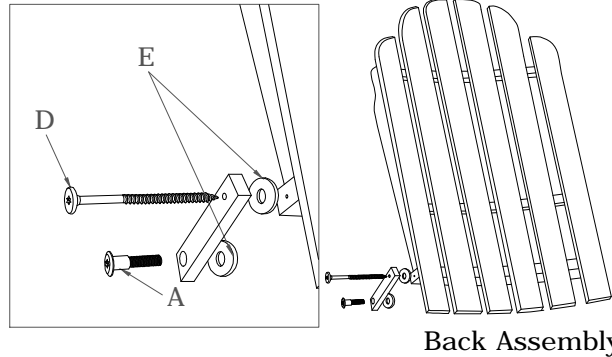
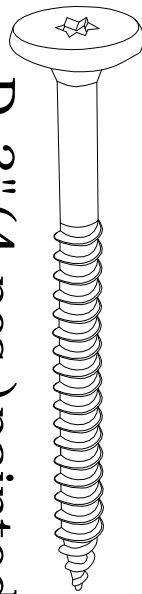

Back Assembly

STEP 4

4. Attach Pivot Arm to Back Assembly as shown in the detail drawing above.

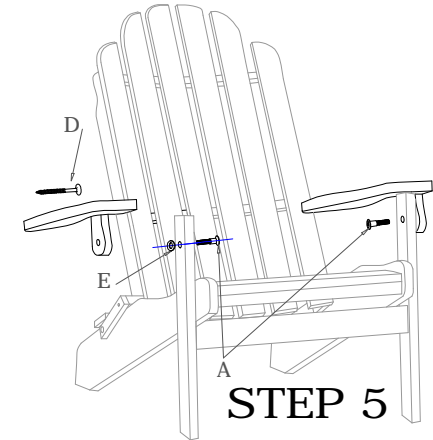

STEP 5

5. Attach Arm Rest Assemblies using Bolt (A) with washer (E) between Legs and Arm Rest connection point.

LIST OF PARTS

- Back Assembly (1)
- Seat Assembly (1)
- Front Legs (2)
- Front Spreader (1)
- Back Spreader (1)
- Pivot Arms (2)
- Arm Rest Assemblies (2)
- Chair Bolts "A" (6)
- Colored Screws "B" (4)
- Colored Screws "C" (2)
- Lg. Headed Screws "D" (4)
- Washers "E" (6)
- Insert Bit Tool (1)

6. After folding down the legs as shown in step 5, attach the Pivot Arm and Back Assembly to the Seat Base using Bolt (A) and Washer (E). Stand Chair and from back of Seat Assembly attach Arm Rest with Screw (D).

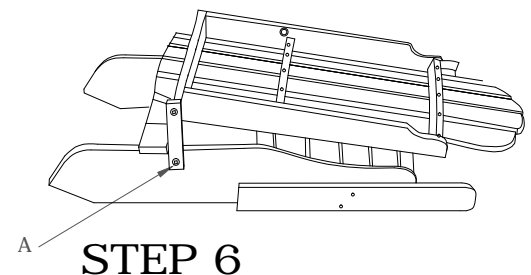

STEP 6