

PARTS			
PART	DESCRIPTION	PART NO.	QTY
A	LEFT SIDE ASSEMBLY	SA-00236	1
B	RIGHT SIDE ASSEMBLY	SA-00237	1
C	LEFT FRONT LEG	PRT-00452	1
D	RIGHT FRONT LEG	PRT-00453	1
E	LEFT ARM	PRT-00454	1
F	RIGHT ARM	PRT-00455	1
G	SEAT SUPPORT	PRT-00457	4
H	FRONT LEFT CENTER LEG	PRT-00913	1
I	FRONT RIGHT CENTER LEG	PRT-00914	1
J	BACK ASSEMBLY	SA-00421	2
K	SOFA FRONT SLAT	SS-72	1
L	SOFA SEAT SLAT	SS-72.5	6
M	FRONT/BACK SPREADER A	PRT-00915	2
N	FRONT/BACK SPREADER B	PRT-00916	2
O	BACK LEFT CENTER LEG	PRT-00917	1
P	BACB RIGHT CENTER LEG	PRT-00918	1
Q	MIDDLE SPREADER	PRT-00921	2

Suggested Tools: Drill, Plastic Mallet

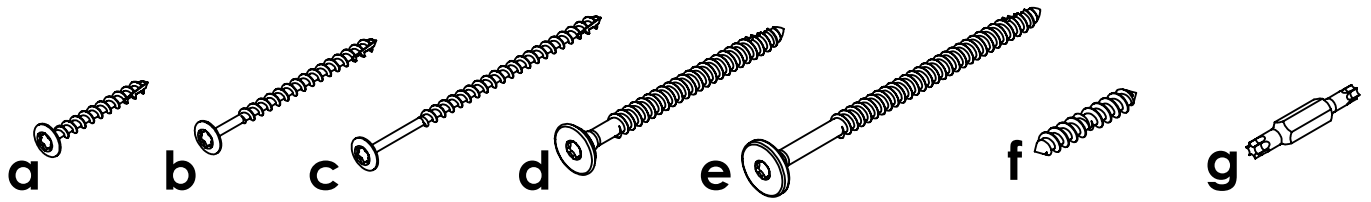

SA-00422 HARDWARE KIT

PART	DESCRIPTION	PART NO.	QTY
a	#8 x 1-1/2" TORX SCREW (22 Frame Color, 28 Slat Color)	H-0000-S815	50
b	#8 x 2-1/2" TORX SCREW	H-0000-S825	25
c	#8 x 3-1/2" TORX SCREW	H-0000-S835	4
d	1/4-10 X 3" LAG SCREW	H-0000-S103	2
e	1/4-10 X 4" LAG SCREW	H-0000-S104	4
f	DOUBLE SCREW	H-0000-DS	2
g	T20 & T25 TORX BIT	H-0000-CTD	1

Please read the entire instruction before beginning

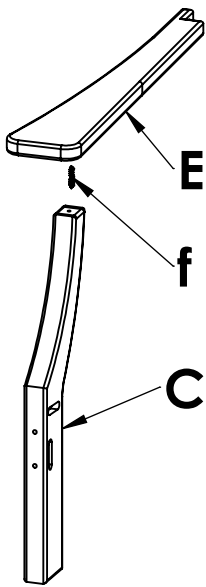

1. Attach Part E to Part C with Hardware f by rotating Part E clockwise, stopping when the assembly is tight

2. Repeat Step 1 with Parts F & D

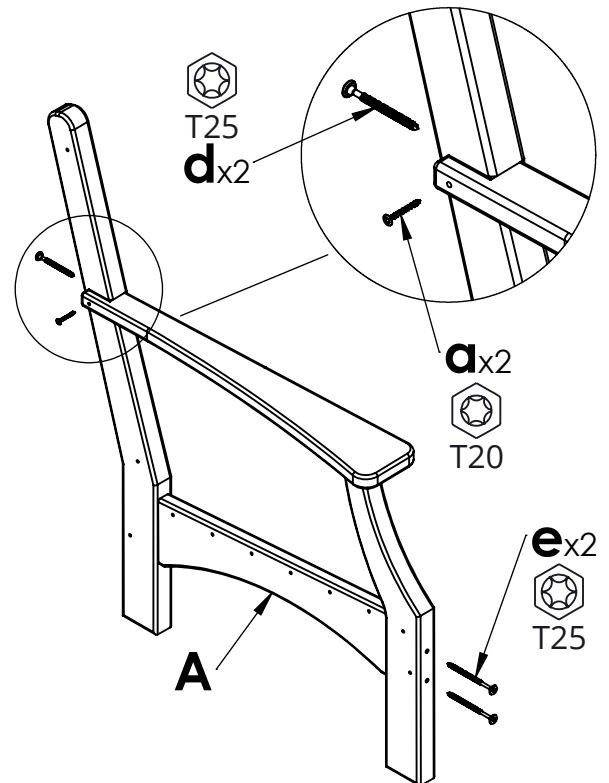

3. Connect Part A to the assembly of E & C using the hardware shown

4. Repeat Step 3 with Part B & the assembly of F & D

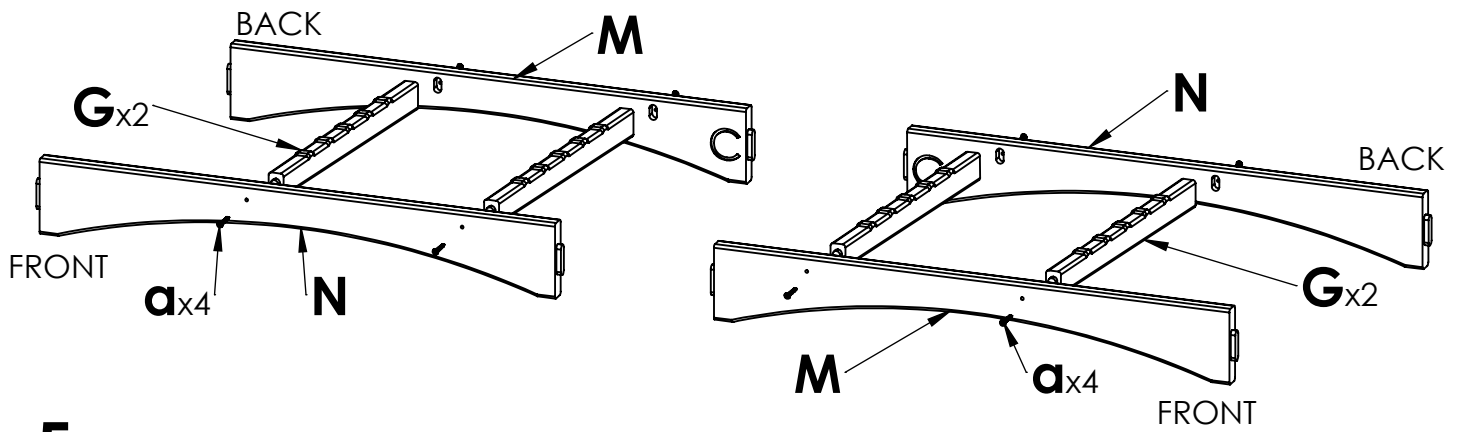

5. Attach Part N to Part M with with 2 of Part G as shown. Fasten using Hardware a. The letter C on the back of the board will be toward the center of the sofa.

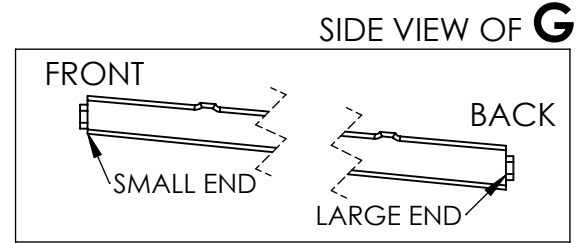

6. Repeat Step 5 with Parts N & M reversed.

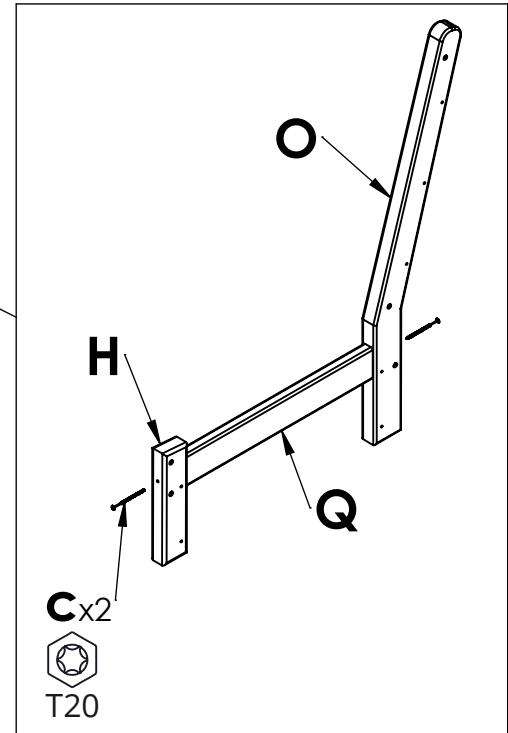
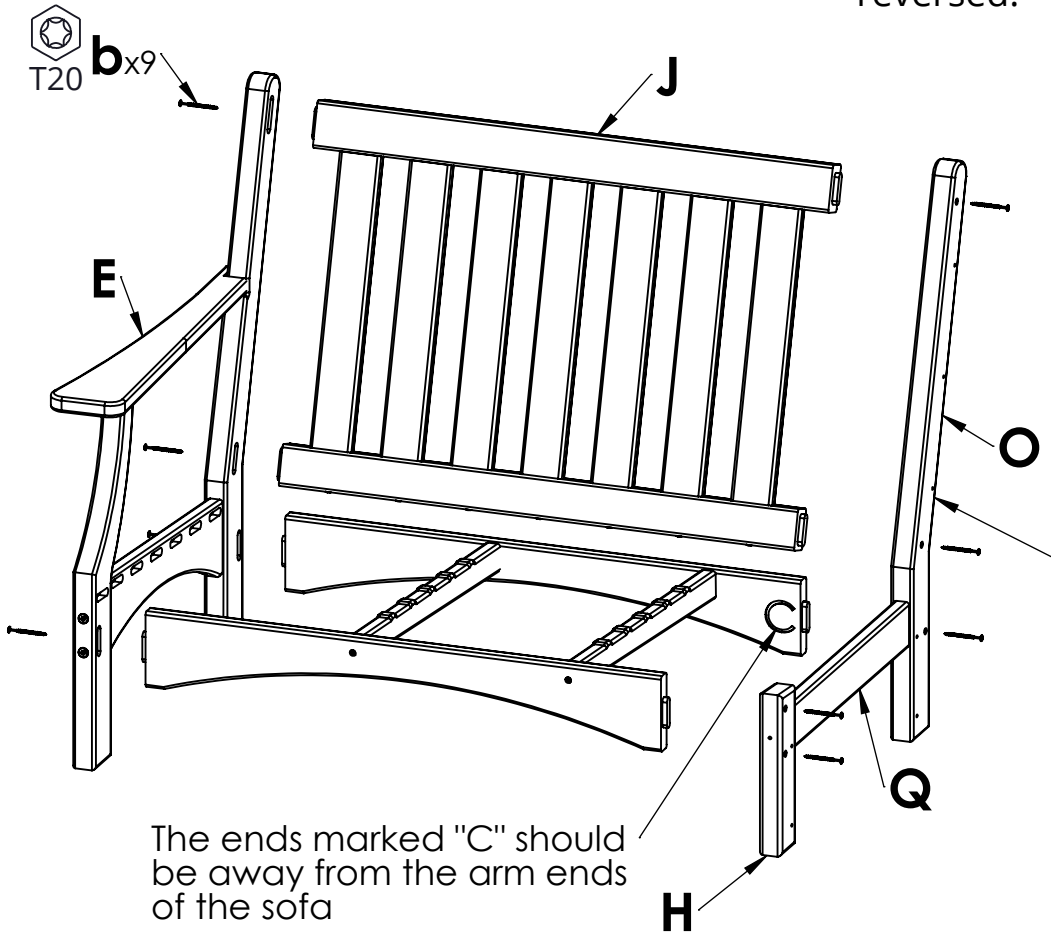

7. Connect Parts O, Q & H using hardware c. Connect this assembly to J and the other 2 previous from Steps 3 & 5 using Hardware b.

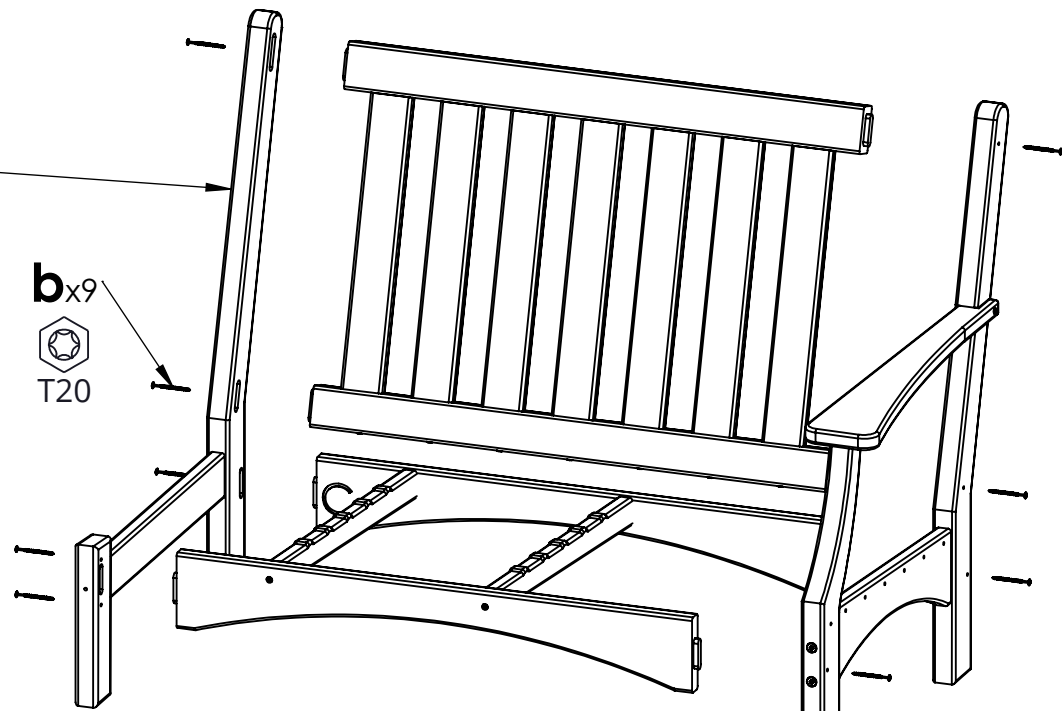
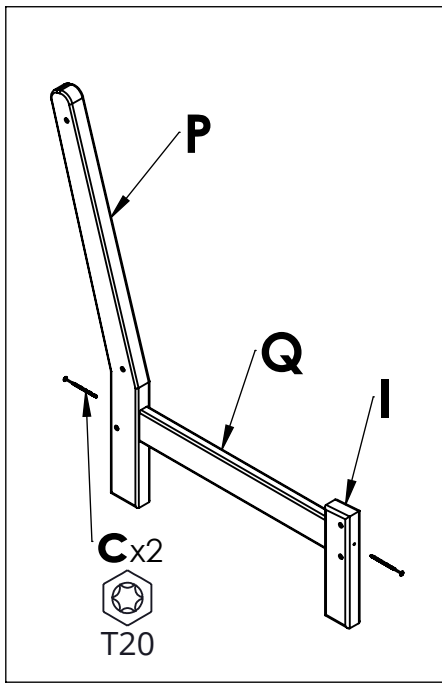

8. Connect Parts P, Q & I using hardware c. Connect this assembly to J and the other 2 previous assemblies from Steps 4 & 6 using Hardware b.

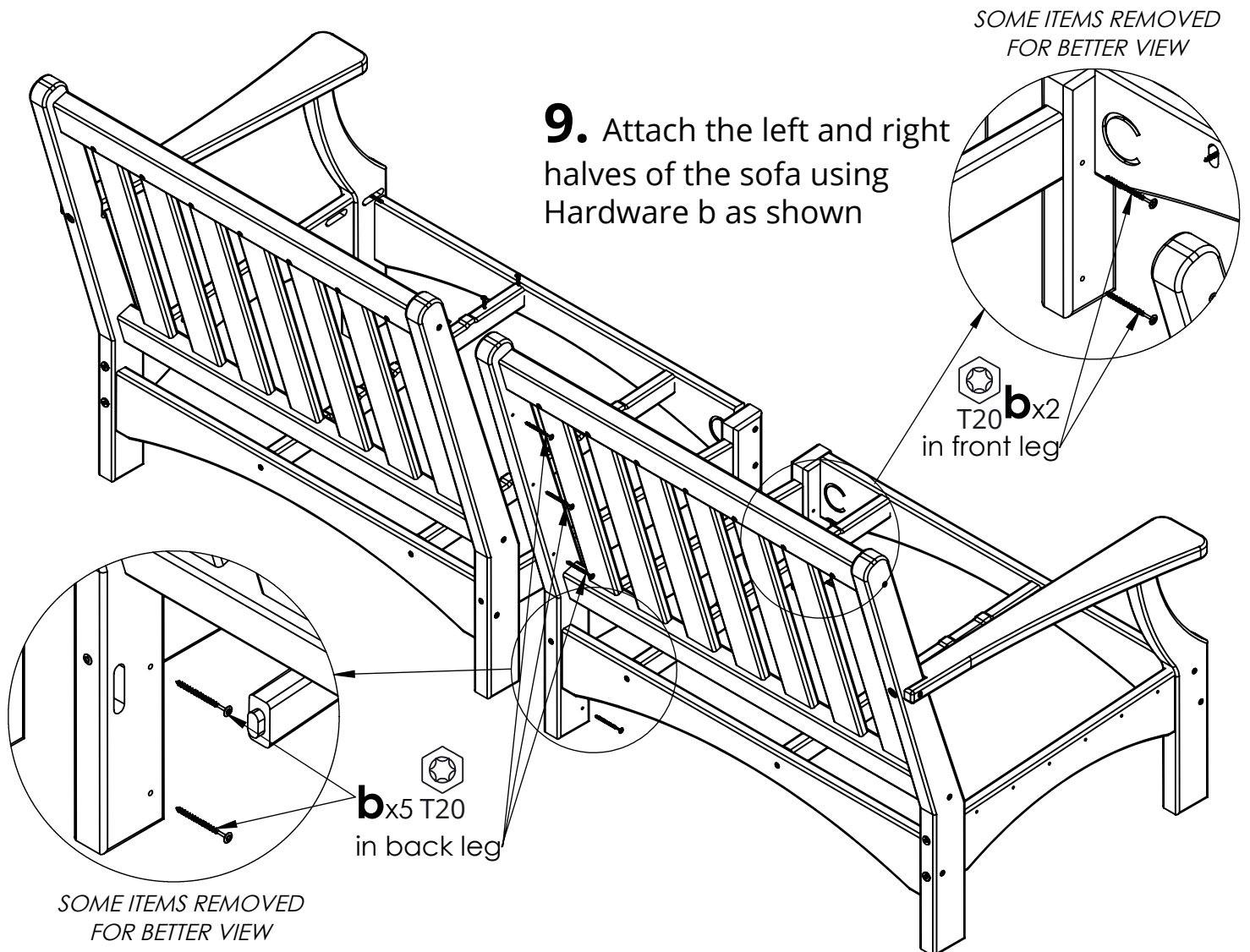

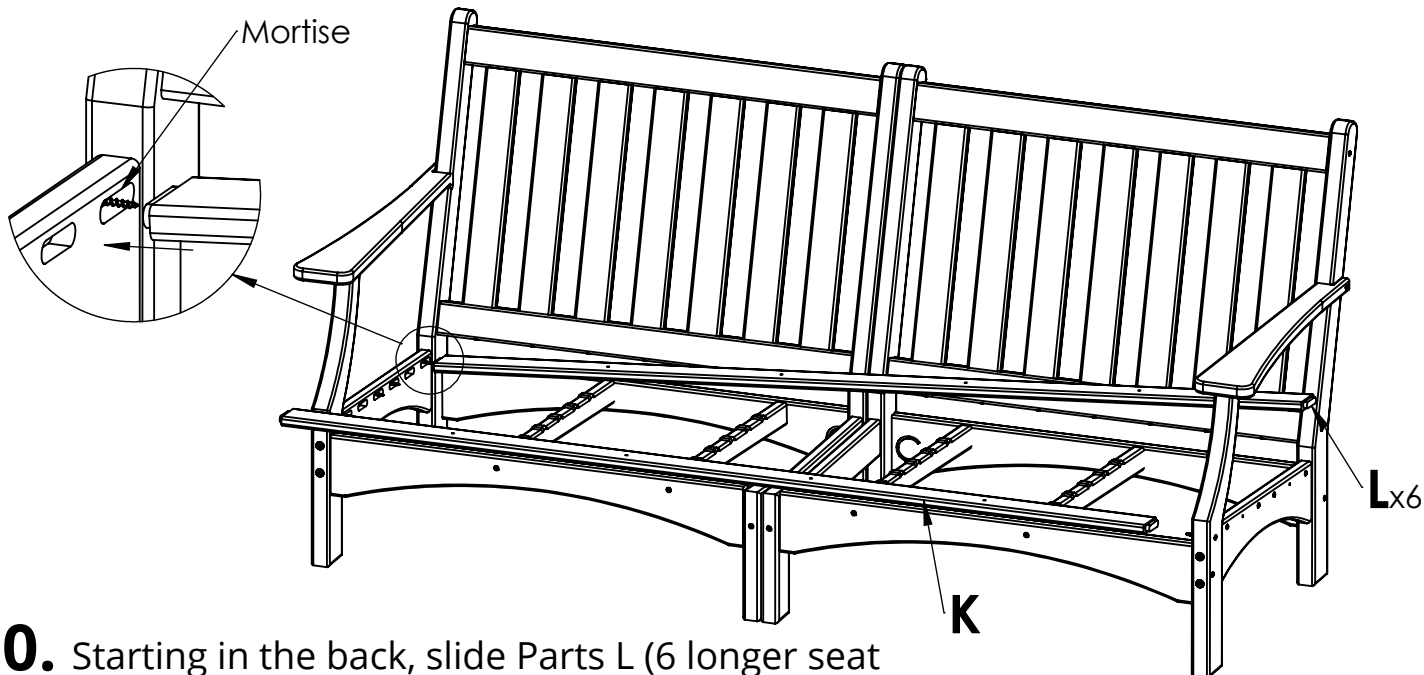

10. Starting in the back, slide Parts L (6 longer seat slats) into the mortise and flex them to fit into the opposite mortise, finish with Part K (the shorter seat slat) on the front of the assembly.

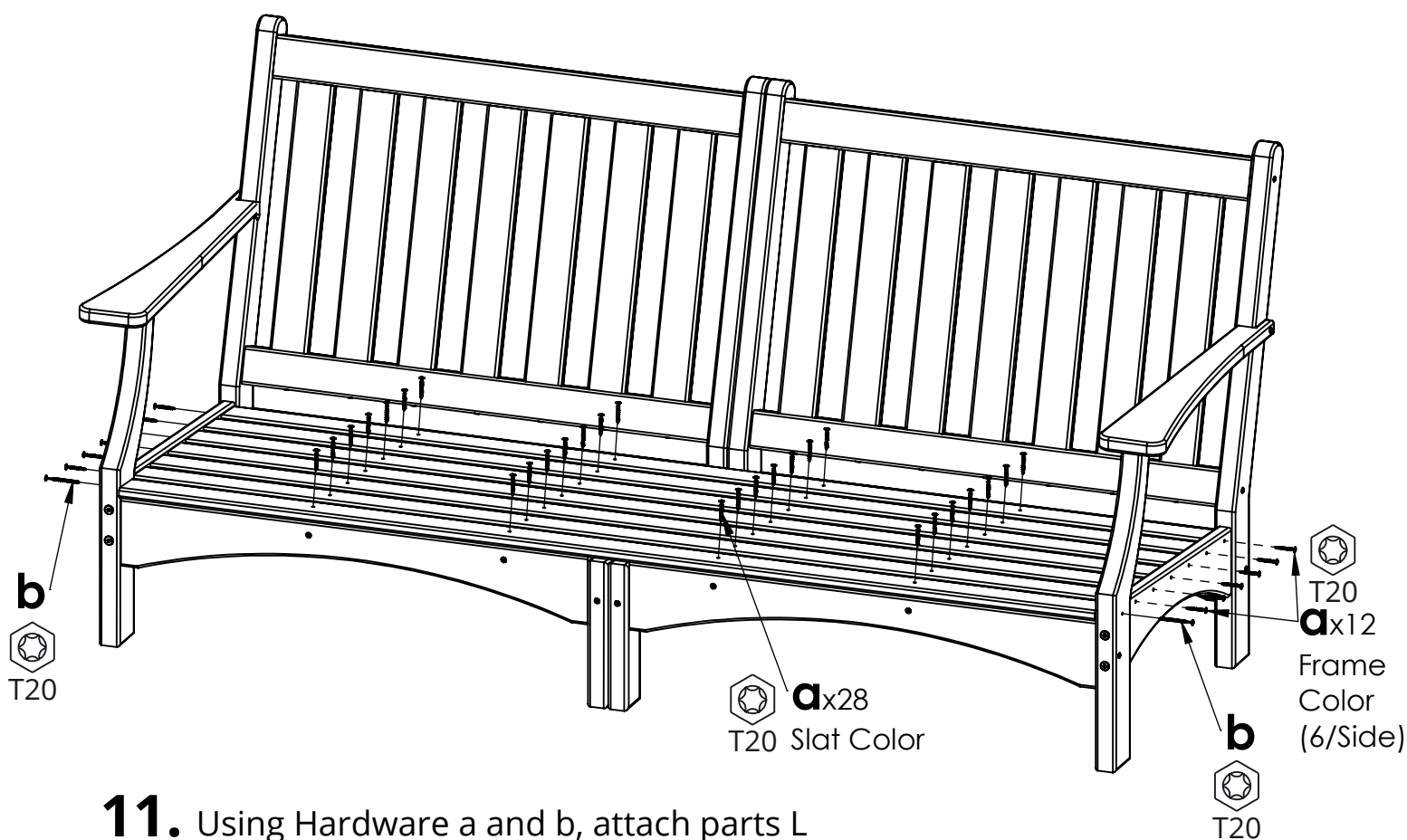

11. Using Hardware a and b, attach parts L and K to the assembly as shown. If the sofa is two-color, use the colors specified.

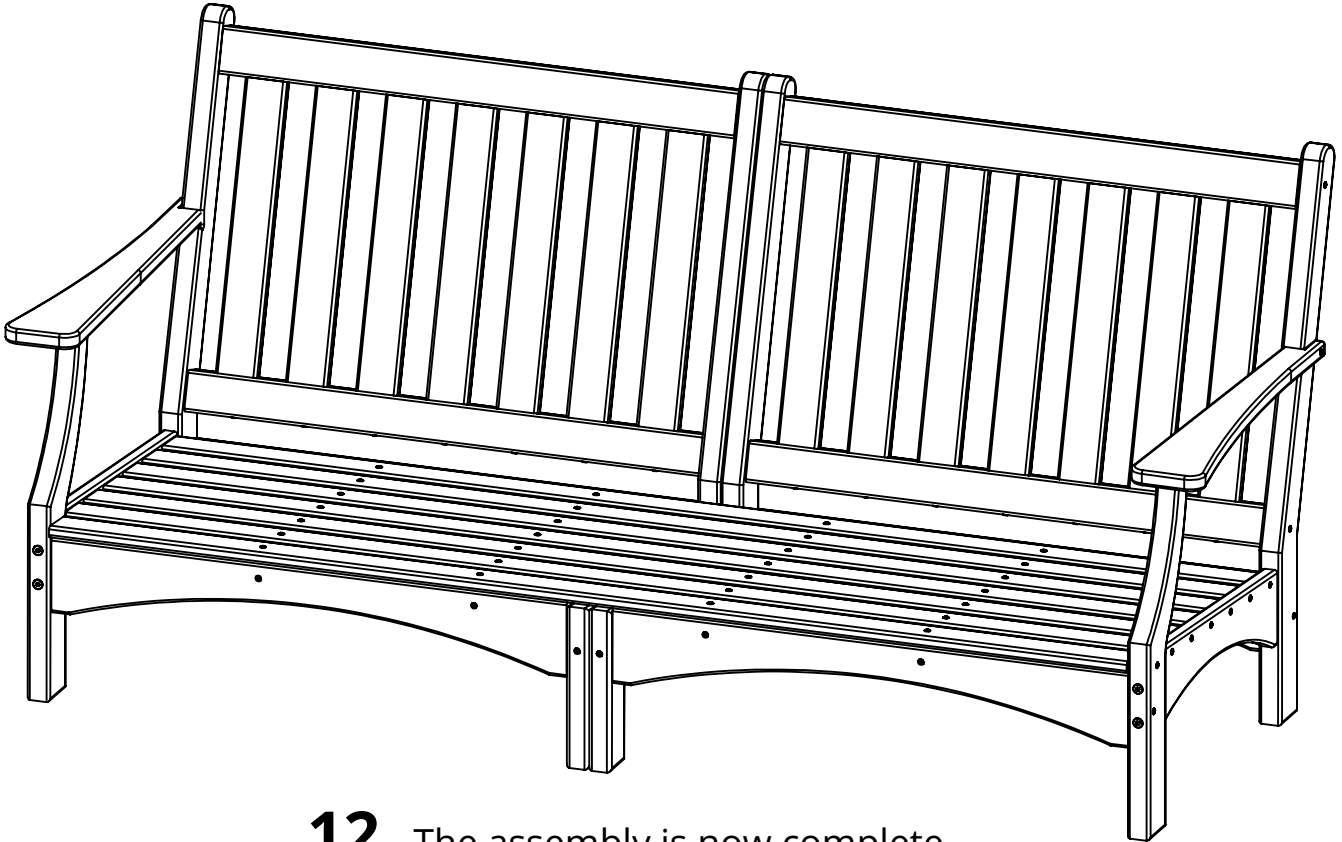

12. The assembly is now complete