

breezesta™

42"x 70" PIEDMONT DINING TABLE
PT-0700

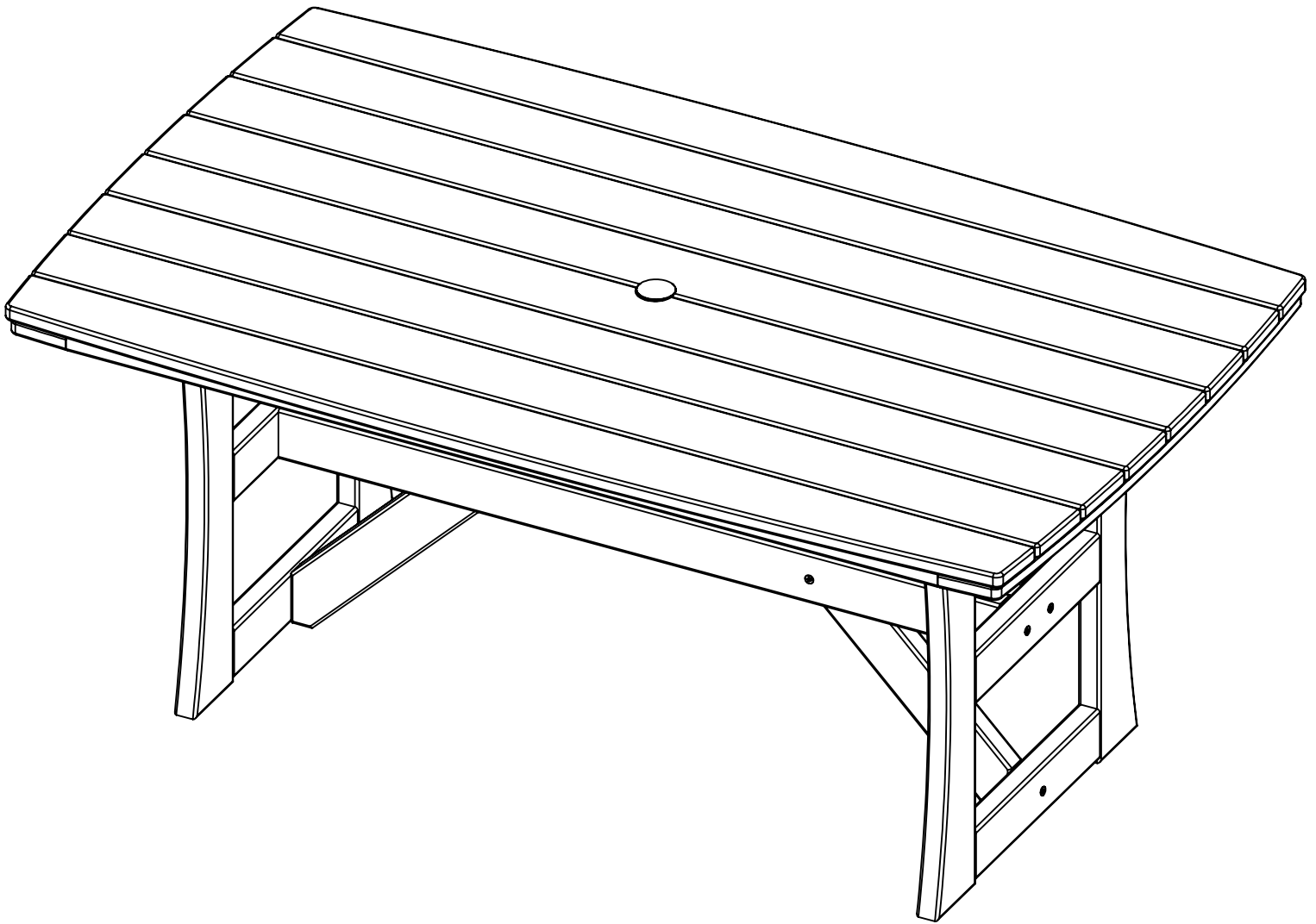

REV01-4/19

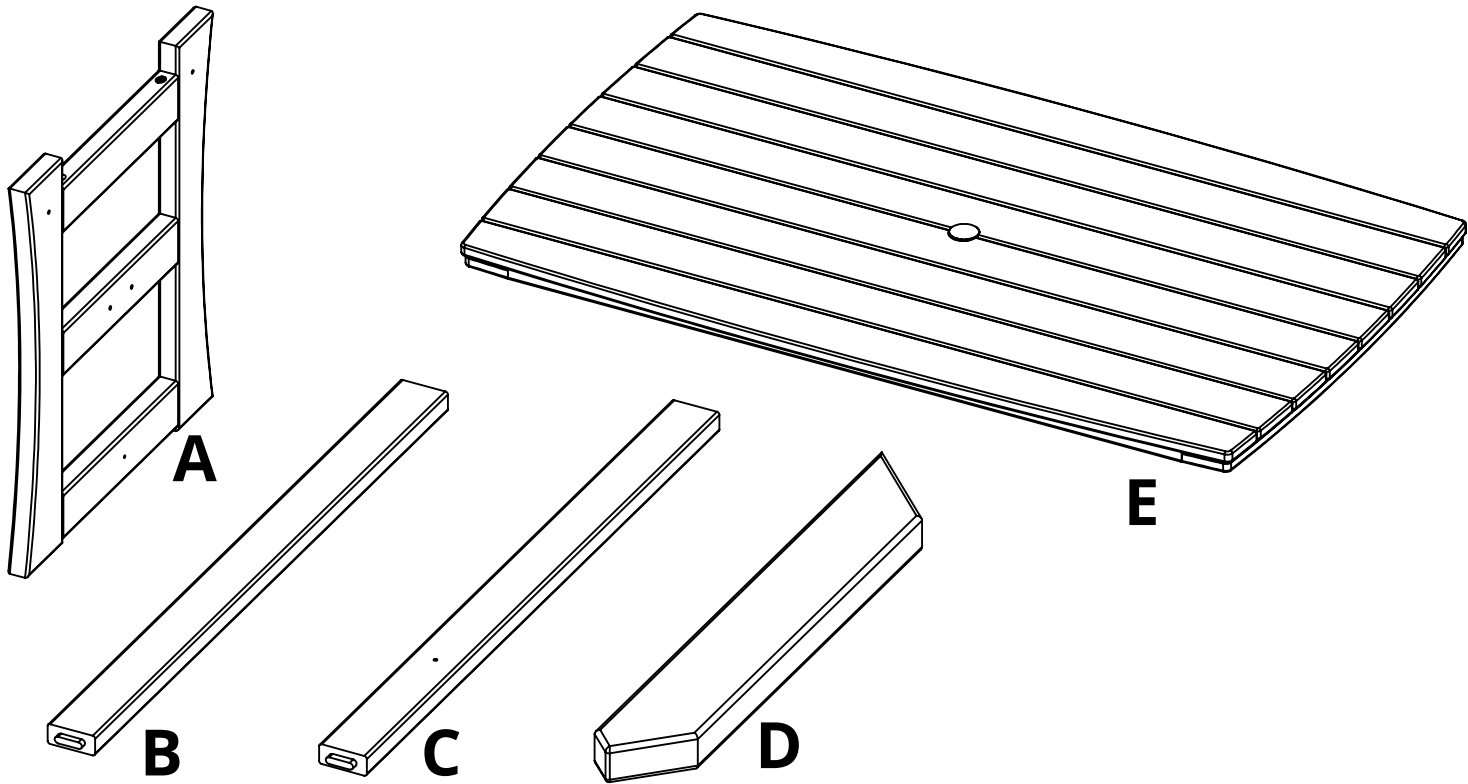

PARTS			
PART	DESCRIPTION	PART NO.	QTY
A	SIDE ASSEMBLY	SA-00271	2
B	TOP SPREADER	PRT-00537	2
C	MIDDLE SPREADER	PRT-00538	2
D	SPREADER GUSSET	PRT-00539	2
E	TABLE TOP ASSEMBLY	SA-00272	1

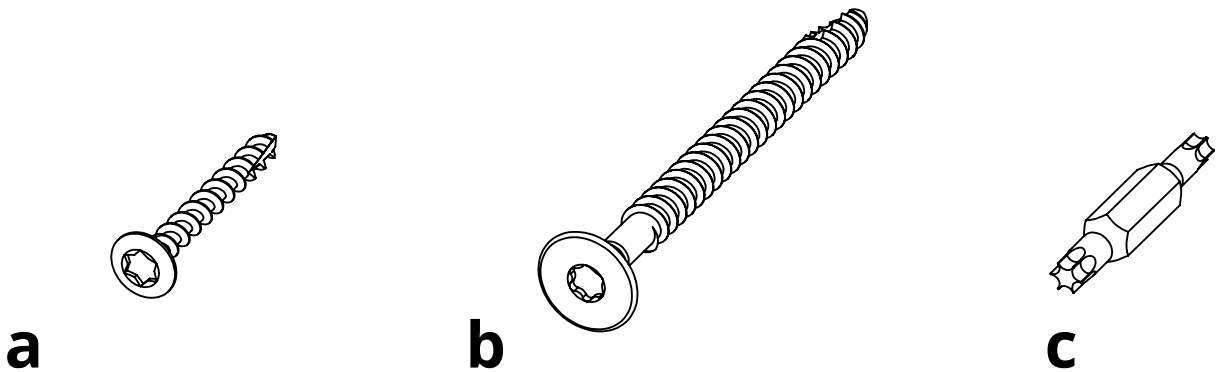

HARDWARE			
PART	DESCRIPTION	PART NO.	QTY
a	#8 X 2" TORX SCREW	H-0000-S82	4
b	1/4-10 X 3" LAG	H-0000-S103	12
c	TORX BIT	H-0000-CTD	1

Suggested Tools: Drill, Plastic Mallet

Please read entire instructions before beginning

- 1.** Attach Part B and Part C to Part A using Hardware b

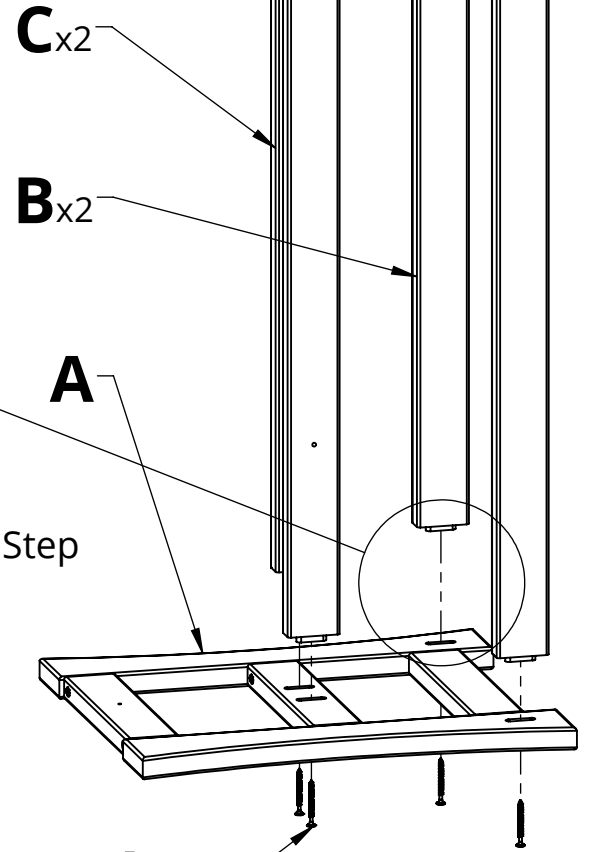
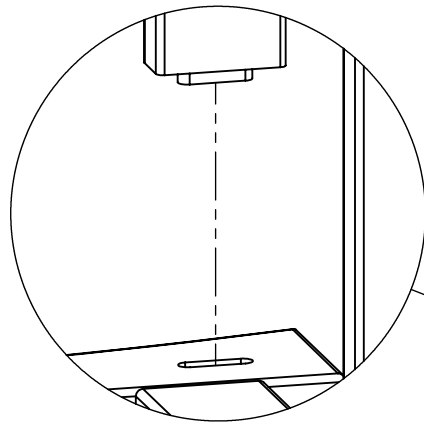

- 2.** Place second Part A on assembled piece from Step 1 & repeat Step 1

- 3.** Insert Part D between Parts C, attach using Hardware b as shown

D_{x2}

b_{x4}



T25

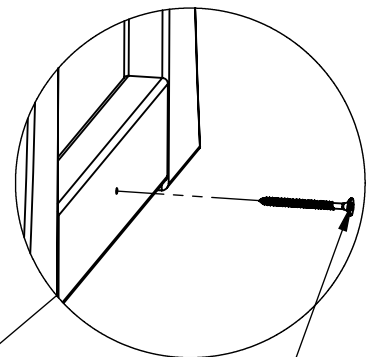
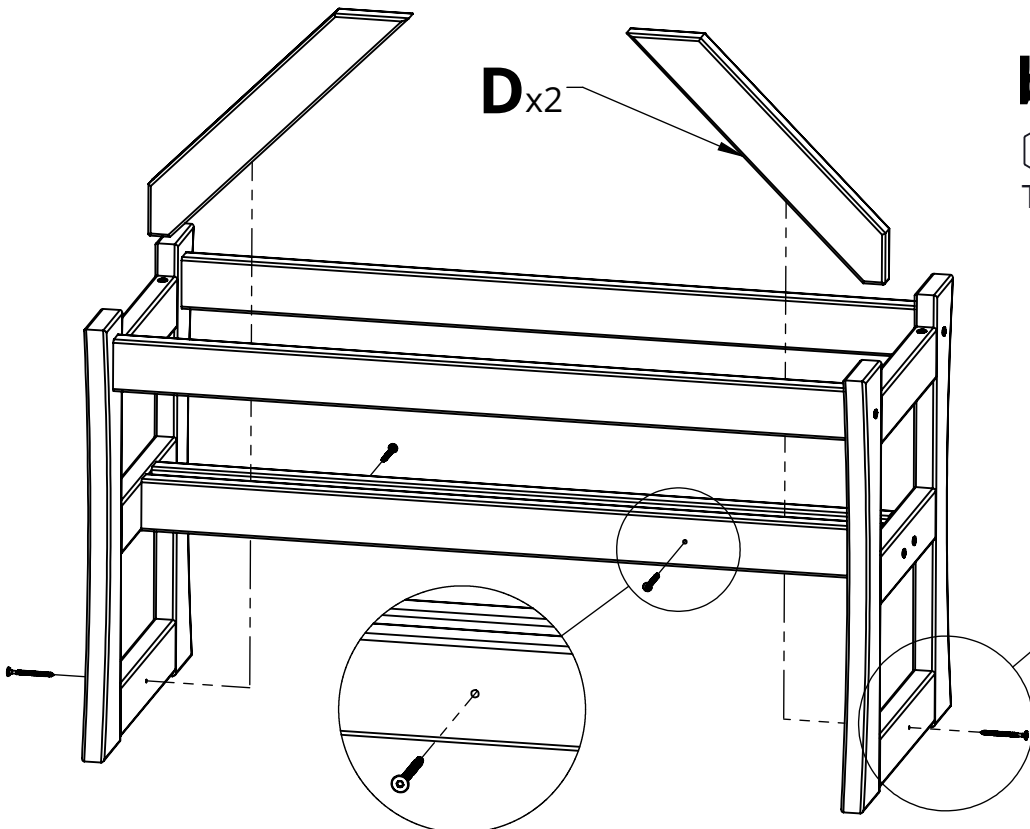

b_{x4}

T25

4. Attach Part E onto previously assembled piece using Hardware a, as shown

